



US 20130213637A1

(19) **United States**

(12) **Patent Application Publication**

Kearl

(10) **Pub. No.: US 2013/0213637 A1**

(43) **Pub. Date: Aug. 22, 2013**

(54) **MICROWAVE SYSTEM AND METHOD FOR INTRINSIC PERMEABILITY ENHANCEMENT AND EXTRACTION OF HYDROCARBONS AND/OR GAS FROM SUBSURFACE DEPOSITS**

Publication Classification

(51) **Int. Cl.**
E21B 43/24 (2006.01)
(52) **U.S. Cl.**
CPC *E21B 43/2401* (2013.01); *E21B 43/2405* (2013.01)
USPC **166/248; 166/57**

(71) Applicant: **Peter M. Kearl**, Grand Junction, CO (US)

(72) Inventor: **Peter M. Kearl**, Grand Junction, CO (US)

(21) Appl. No.: **13/768,516**

(22) Filed: **Feb. 15, 2013**

Related U.S. Application Data

(60) Provisional application No. 61/633,730, filed on Feb. 17, 2012.

(57) **ABSTRACT**

A system of a radiating antenna and a sheet beam klystron, as a microwave source, coupled to the antenna by a short waveguide and the method of locating the antenna downhole in a well at a selected target zone by use of a dual chamber flexible tube and applying power to the source to heat and fracture the rock in the target zone and created a migrating phase boundary that radiates out from the antenna 25 meters or more to release the hydrocarbons in the rock.

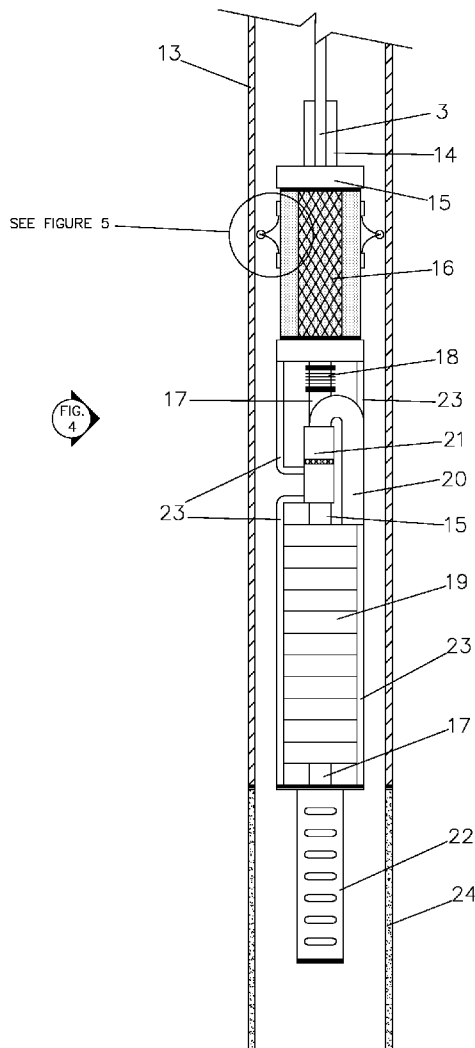

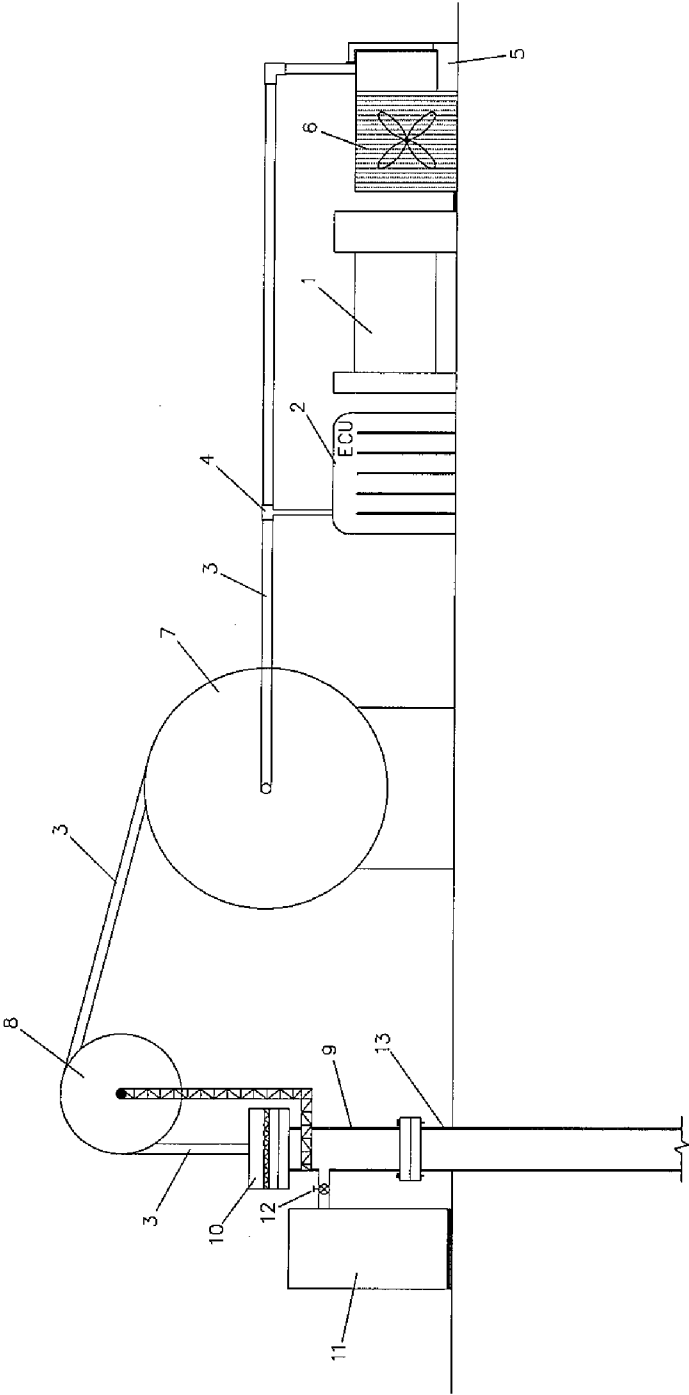

FIGURE 1

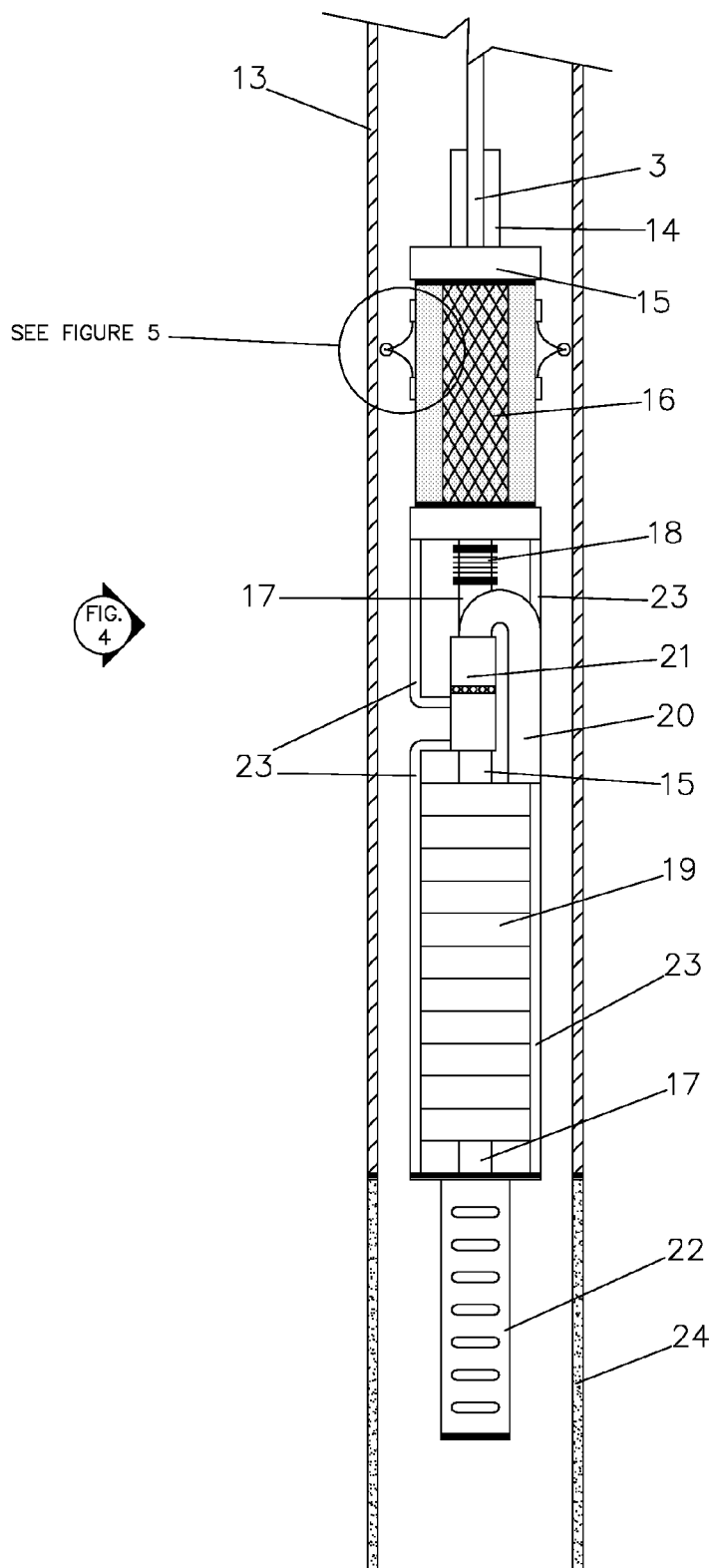

FIGURE 2

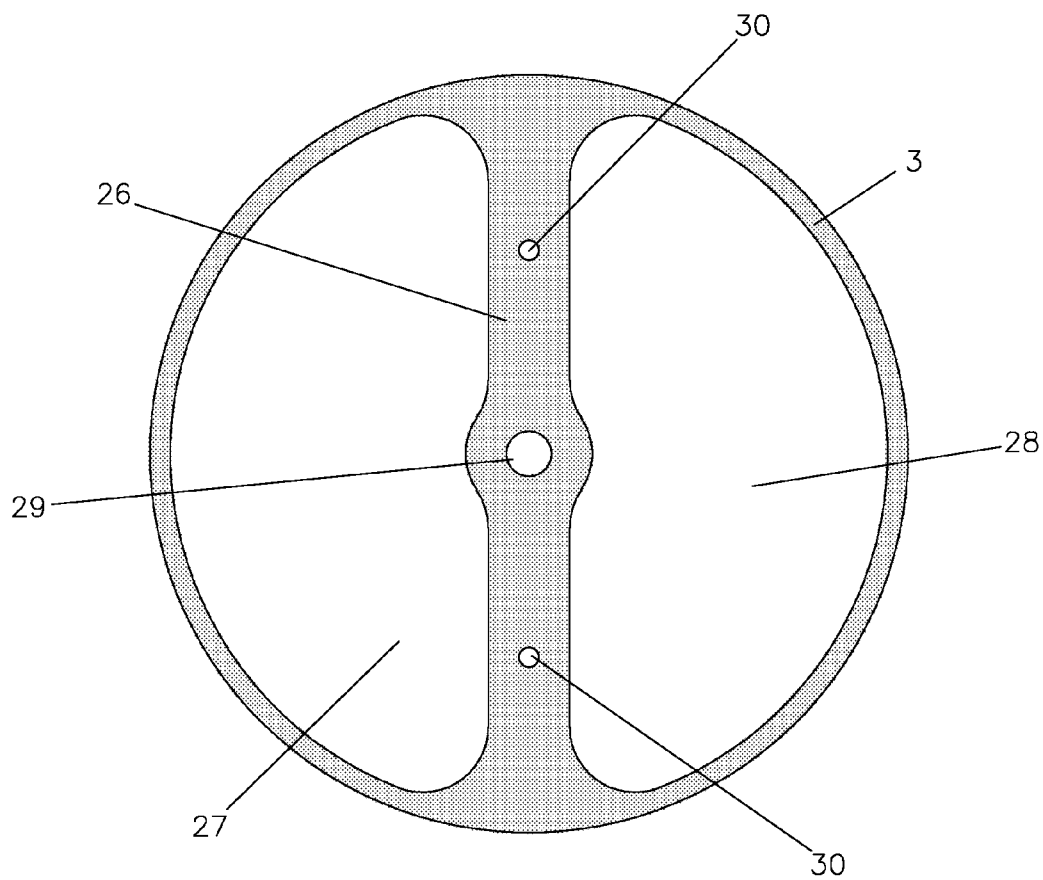

FIGURE 3

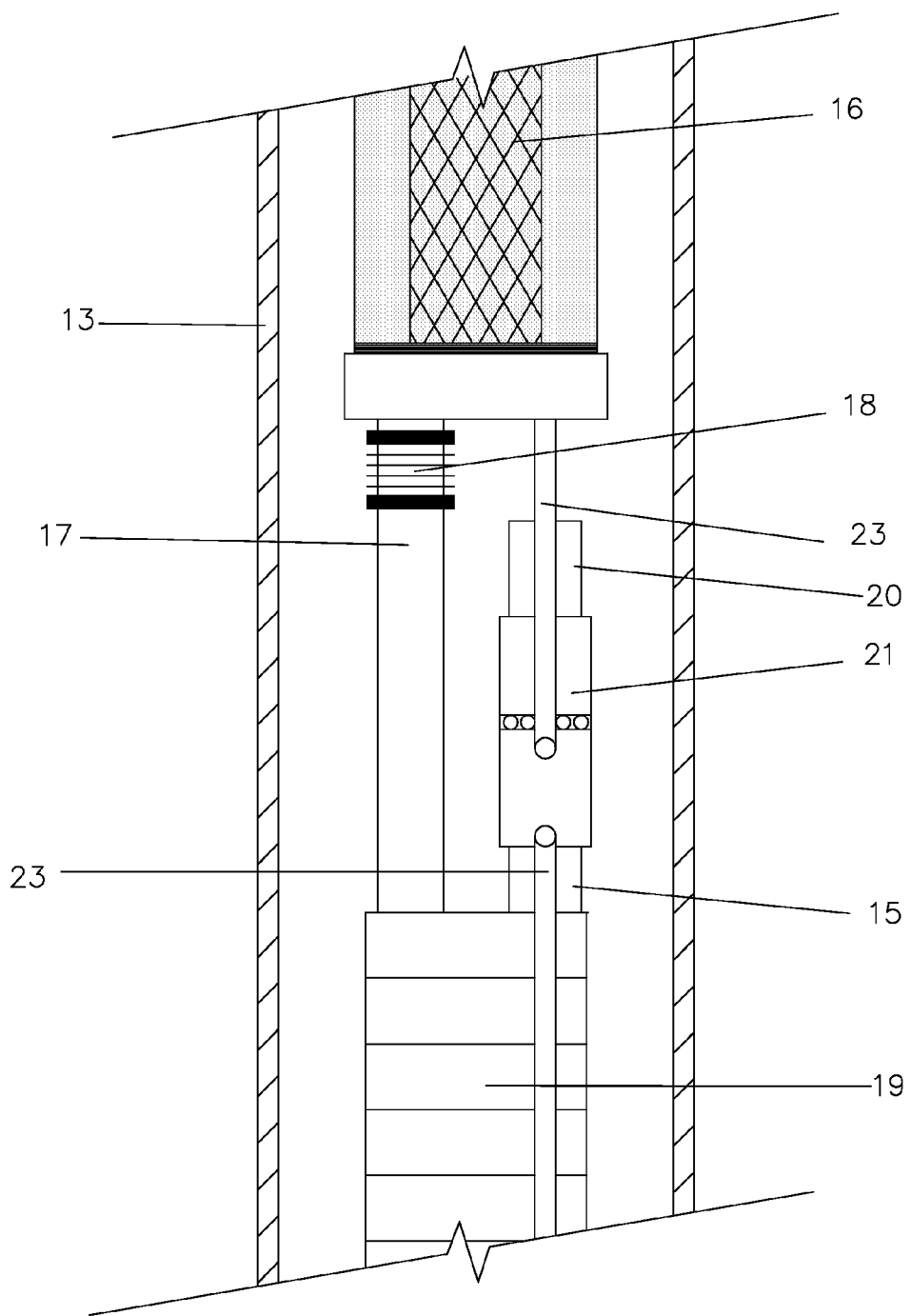

FIGURE 4

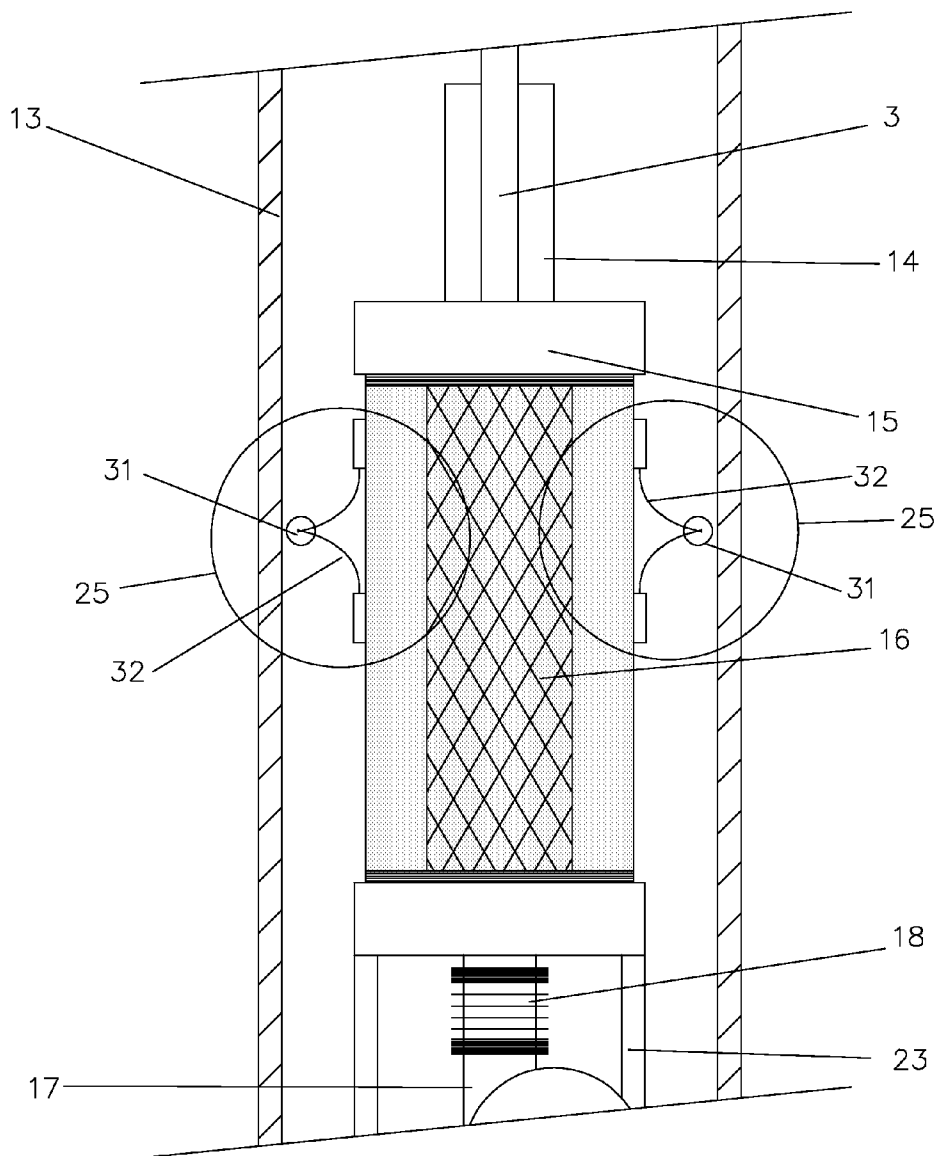

FIGURE 5

**MICROWAVE SYSTEM AND METHOD FOR
INTRINSIC PERMEABILITY
ENHANCEMENT AND EXTRACTION OF
HYDROCARBONS AND/OR GAS FROM
SUBSURFACE DEPOSITS**

CROSS REFERENCE TO RELATED
APPLICATIONS

[0001] This Application claims priority to and benefits of U.S. Provisional Application No. 61/633,730 filed Feb. 17, 2012, the entire contents of which is hereby expressly incorporated by reference.

FIELD OF THE INVENTION

[0002] The present invention relates to a downhole High Power Microwave (HPM) System and methods of using the System, which are capable of fracturing rock and increasing primary permeability in rock at depths (subsurface "Target Area") consistent with hydrocarbon production by utilizing in-situ water and hydrocarbon contents to selectively heat and remove hydrocarbons, including gas, from fractured rock. "Hydrocarbons", as used herein, include gas and liquids.

BACKGROUND

[0003] This application expressly incorporates by this reference, as though set forth in full, U.S. Pat. No. 7,828,057 assigned to Peter M. Kearl (inventor herein) dba Geoscience Service and United States Patent Application Publication Number 2008/0265654.

[0004] Oil shale, tar sands, oil sands and subsurface media in specific areas contain useful recoverable hydrocarbons. For example, it has been reported that there are vast oil shale deposits in the United States, and in particular, in the States of Colorado, Utah and Wyoming; with over 1.5 trillion barrels of oil in the oil shale in these States. Recently, there has been interest expressed in recovering the hydrocarbons from shale in numerous geologic basins throughout the United States and the world. There have been many attempts to extract the hydrocarbons from this type of subsurface deposits.

[0005] Some of these applications involve removal of the subsurface media to above ground and the use of a retort to remove the oil. To avoid the step of excavating or mining, a number of in-situ processes have been proposed.

[0006] One proposal employs relatively low power at low frequencies supplied by a magnetron. The microwave generator is a mixer apparatus similar to those used in microwave ovens and is relatively ineffective for controlled heating and removing of hydrocarbons. This downhole magnetron is disclosed in U.S. Pat. No. 4,193,448 issued Mar. 18, 1980 to Calhoun G. Jeambey, as inventor, and the use of this generator is disclosed in detail in U.S. Pat. No. 4,817,711 issued Apr. 4, 1989 to Calhoun G. Jeambey, as inventor. The proposal by Jeambey uses low frequencies and relies on ionic heating, pulse power that allows conductive heat losses and relative low power levels. This system will not produce an expanding phase boundary by dielectric heating and will not apply sufficient power to reach significant distances into the rock. This is not an effective approach.

[0007] Microwave heating has significant advantages over low frequency heating (generally less than 1.0 gigahertz) for the extraction of subsurface hydrocarbons. The imaginary part of the permittivity ϵ_r'' (the loss tangent ϵ_r''/ϵ_r') is a measure of how dissipative a medium is and gives the rate of

attenuation to a propagating wave. In the lower RF frequency ranges, ϵ_r'' is dominated by ion conductivity. As rock is heated by a low frequency RF source, ions in groundwater will act as a charge carrier until approximately 100 degrees centigrade is achieved, depending on the system pressure, at which time the water will vaporize, terminating the charge carrier pathway. Further heating of the rock will rely on conduction that requires large energy inputs over substantial time periods to achieve desirable results. For example, kerogen locked in oil shale requires temperatures in the range of 450 to 500 degrees centigrade in order to liquify for removal. This requires an additional 350 to 400 degrees centigrade heating by conduction for RF frequency heating applications.

[0008] Although not designed for commercially recovering hydrocarbons from oil shale or other subterranean locations, a high power microwave system is disclosed in U.S. Pat. No. 5,299,887 issued Apr. 5, 1994 to Donald L. Ensley. This system is disclosed for the removal of contaminant from a sub-surface soil matrix. It is taught in this patent that the application of high power microwave energy to chlorinated hydrocarbons contaminated (CHC) soil causes micro-fractionation of various soil aggregates, including clay and rock formations. This effect increases the local permeability and resulting diffusion rates for egress of both liquid and vapor phase CHC.

[0009] The teachings of the Ensley U.S. Pat. No. 5,299,887 patent were included in U.S. Pat. No. 6,012,520 by Andrew Yu and Peter Tsou as an alternative to the use of high-pressure water jet drilling to create a high-permeability web in a hydrocarbon reservoir.

[0010] These systems of Ensley, Yu and Tsou and the system disclosed in the U.S. Pat. No. 7,828,057 and the application Publication Number 2008/0265654 involve a microwave source and its attendant components located on the surface near the well or near the contaminates to be removed from the soil. The equipment is too large to fit downhole and does not have the components necessary to function downhole.

[0011] However, while not using the above technology, advances in the extraction of hydrocarbons from low permeable reservoir rocks have greatly expanded energy options for a number of countries. Common practice for increasing subsurface permeabilities for petroleum and other hydrocarbon reservoir rocks, especially shale formations, involves hydrofracturing where liquids and sometimes hazardous chemicals are injected into subsurface rock formations under high pressures to fracture the rock and provide a pathway for the extraction of hydrocarbons. This practice has raised concerns of potentially toxic chemicals contaminating groundwater, well failures resulting in surface spills, and leakage from surface impoundments resulting in the pollution of local water supplies. Nevertheless, technologies capable of in-situ extraction of hydrocarbons with minimal environmental impacts have a bright future in the global economy.

SUMMARY

[0012] In some embodiments, the present invention is a method of inducing increased permeability at a selected target area downhole in a well comprising lowering to the target area a system including a sheet beam klystron as the source of microwave energy, a recirculator, a dummy load, and a directional antenna.

[0013] The method may further include positioning the antenna in the target area and pointing it in a selected direction, applying DC power to the klystron through a power

cable from a generator on the surface or applying the DC voltage at a selected low level and then increasing the voltage to an operating level in response to a measured parameter downhole or on a set schedule, employing a dual chamber flexible tube for lowering the system to the target area, and recirculating a coolant from the surface through one chamber, downhole in contact with the source of microwave energy, recirculator, dummy load and antenna and back to the surface through the second chamber in the flexible tubing.

[0014] In some embodiments, the present invention is a method of intrinsic permeability enhancement at a selected subsurface level to release hydrocarbons at the selected subsurface level by employing a sheet beam klystron as the source of microwave energy coupled to a directional antenna, the method comprising positioning the source downhole near the directional antenna and positioning the directional antenna at the selected subsurface level and applying power to the source of microwave energy. The rock may then be fractured at the selected level and increasing the rock permeability by increasing the interconnected porosity resulting in increased hydrocarbon delivery efficiency.

[0015] In some embodiments, the directional antenna covers a sector, such as 30 degrees or 60 degrees, and is rotated to cover a new sector when the enhancement is determined to be sufficient or complete.

[0016] In some embodiments, the present invention is a system for in-situ extraction of hydrocarbons from a target formation in a well comprising: a casing in the well, a well screen of low dielectric material at the lower end of the casing in the target formation, a source of microwave energy and a radiating antenna positioned in the casing at the target formation, and a short waveguide coupling the source of microwave energy to the antenna.

[0017] In some embodiments, the present invention is a system for creating a subsurface permeable cylinder by fracturing an unfractured rock at selected depths comprising a radiating antenna and a source of microwave energy near the antenna to expose a large surface area of unfractured rock to allow low hydrocarbon desorption rates that are compensated with large cross sectional areas for efficient and productive gas wells.

[0018] In some embodiments, the present invention is a method of creating a subsurface permeable cylinder as a reservoir comprising fracturing the rock at selected depths by a downhole system including a radiating antenna and a source near the antenna to expose a large surface area of unfractured rock and sequestering carbon in the cylinder. The reservoir may be pressurized and located near hydrocarbon producing wells to enhance the hydrocarbon production.

BRIEF DESCRIPTION OF THE DRAWINGS

[0019] FIG. 1 is a diagram of the surface components of the High Power Microwave System, in accordance with some embodiments of the present invention.

[0020] FIG. 2 is a front elevation view of the downhole components of the High Power Microwave System with the cylindrical casing and cylindrical sleeve shown in cross-section and the well bore not shown, in accordance with some embodiments of the present invention.

[0021] FIG. 3 is a cross sectional diagram of the flexible tubing with reinforced power cables and cooling tubes, in accordance with some embodiments of the present invention.

[0022] FIG. 4 is a left side elevation view of components of the System shown in FIG. 2, in accordance with some embodiments of the present invention.

[0023] FIG. 5 is a front elevation view of the carriage used for the insertion and positioning of the System, in accordance with some embodiments of the present invention.

DETAILED DESCRIPTION

[0024] The downhole high power microwave system and proposed methods disclosed in this application provide an alternative to hydrofracturing that is environmentally sensitive and has the potential to improve fracturing efficiencies. One potential improvement of significance is that the released hydrocarbons can be extracted from the well while the microwave fracturing by a sheet beam klystron is taking place. Another improvement is that chemicals, which are objected to by some, are not needed.

[0025] The microwave fracturing is accomplished by the high power microwave system and the method of placing the system at the selected level (the target area) and controlling the fracturing from the surface. The surface components of the proposed downhole system include a 400 cycle turbine generator, or similar source, which supplies electrical power for the system. The output of the electrical generator is applied to an electrical control unit that contains, but is not limited to, a crowbar, a transformer, a filter and a power supply to provide DC power to the subsurface or downhole high power microwave system. A reinforced flexible tube, which is compartmentalized, carries electrical wire to power the downhole microwave system, has a pair of chambers to carry coolant to and from the system downhole and carries a selected number of wires for monitoring the downhole conditions, such as temperature and pressure, and for control signals for various functions downhole, such as moving the system up, down or rotational. A high capacity cooling system is connected to the flexible tube through a pump to maintain an adequate supply of coolant for the downhole high power microwave system. This coolant may be a typical coolant, and a particularly good coolant is water, for example. The system is deployed downhole by using a large motorized drom capable of holding substantial lengths of flexible tubing and interchangeable with additional drums depending on the depths to be treated. A pulley, connected to the well head manifold, directs the system into the well. A blow out preventer, common to oil and gas wells, is employed. A compression assembly secures the tube and provides an air tight seal during operation of the system.

[0026] The well head manifold directs vapors from the well to a condenser that collects hydrocarbon vapors or directs them to the power generator as a fuel source. A valve is used to control downhole pressure for development of superheated fluids from in-situ water or other in-situ fluids to aid in the extraction of hydrocarbons. The well may be encased, with the casing extending from the surface and almost to the subsurface target area. Also the well may not have the usual casing, but may be encased over a selected length from the lower end up the selected distance with a low dielectric loss sleeve or casing.

[0027] The major system components placed downhole are the termination of the components in the flexible tube, a high power microwave source, preferably a sheet beam klystron, a directional antenna, a dummy load and a recirculator to direct the microwave beam to the antenna and reflected waves to the dummy load. The system further includes an orientation tool,

which may be a carrier having flexible positioning arms and motorized wheels, that allows surface operators to place the antenna at the desired depth and radiation direction. Commonly used well field tools such as, but not limited to, gyroscopes or flux gate compasses provide the information for orientation of the system in various directions. The flexible tube, with power and instrument cables, is attached to a manifold near the microwave source which directs power and the cooling system to the sheet beam klystron tube and other components. The sheet beam klystron tube provides, but is not limited to, 1 megawatt (MW) of power at a frequency of, but not limited to, 6 to 8 GHz. Microwave power is emitted from the klystron tube via a short wave guide, with an arc detector, to the recirculator. A purpose of the recirculator is to protect the klystron tube by shifting the phase of reflected power to a separate output wave guide connected with the water or coolant cooled dummy load where reflected power is coupled into coolant, such as water, to prevent damage to the klystron tube. The antenna is preferably cooled by the coolant and may be a phased array antenna, for example. The antenna is capable of radiating a directional beam in various radiation patterns depending on the proposed fracture patterns. The antenna radiates in a selected pattern and is directed to cover sectors, such as 30 degrees or 60 degrees, for example. The coolant for the system components is directed by coolant tubes along the klystron, recirculator, dummy load and antenna. The system components listed above are major equipment items. Other components which may be included are additional arc detectors and monitoring equipment.

[0028] Several different applications are possible for emitting microwave radiation into the subsurface while protecting the downhole microwave system. Thus, another component of the system is a low dielectric loss sleeve or a low dielectric loss permeable well casing. Where the hole or bore is encased with casing material like steel, the sleeve is comprised of, but not limited to, a perforated fused quartz or a ceramic cylinder that seats into a shoe at the base of the steel casing. Numerous holes in the fused quartz or ceramic cylinder can be used as a sleeve that will protect the equipment while radiating in a subsurface target area. Using well logging and geophysical data to select target zones, high power microwave energy will be emitted from the antenna in specific patterns to create migrating phase boundaries that will fracture the rock and create specified zones of increased permeability. As a selected zone is completed, the sleeve and the system are pulled back to another target area and the process repeated. The other option is to case a selected length of the well with a permeable low-loss well casing and radiate either selected target zones or the entire target formation through the low loss dielectric sleeve.

[0029] The high power microwave system is designed to either produce hydrocarbons from subsurface target areas or to increase the permeability surrounding the well by increasing interconnected porosity and fracturing the rock by dielectric heating of in-situ water and hydrocarbons. For dielectric heating to efficiently heat the rock, frequencies must be high enough to exclude ionic heating—generally greater than 1 GHz. Efficient dielectric heating for purposes of hydrocarbon removal occurs in the 2 to 10 GHz range, but is not limited to the upper frequency range.

[0030] In use, the system is lowered into the well using the flexible tubing system that contains dual cooling chambers or tubes, reinforced power cable, and instrument cables. The system can be used in either vertical or horizontal wells. The

high power microwave system of a sheet beam klystron, antenna, recirculator, dummy load and ancillary components can be lowered into a vertical shaft or a vertical shaft which curves and becomes a horizontal shaft. A carriage, having preferably motorized wheels and tensioning arms pressing against the inside of the casing and attached to some of the components of the high power microwave system, guides the system down and along the casing. The carriage preferably positions the system in the center of the casing.

[0031] In some embodiments, the method of inducing increased permeability at a selected target area downhole in a bare well or an encased well comprises the steps of lowering a system comprising a sheet beam klystron as the source of microwave energy, a directional antenna, a dummy load and a recirculator coupled between the source and the antenna to direct reflected energy from the antenna to the dummy load. The system is then positioned with the antenna in the target area and pointing in the selected direction. DC power is applied to the klystron through a power cable from a generator on the surface. The DC voltage may be started at a selected lower level and increased to an operating level in response to a measured parameter downhole or on a set schedule.

[0032] In some embodiments, a coolant is sent from the surface through one chamber in the flexible tubing to cool the source, recirculator, dummy load and antenna and then back to the surface through the second chamber in the flexible tubing.

[0033] The temperature of the various components, the pressure of an enclosed well, the frequency of the source and flow rates and other parameters may be measured and controlled during and after fracturing.

[0034] If a sector is covered by the radiation of the antenna, upon completion of the fracturing in this sector the antenna is rotated to cover the next sector. To rotate the antenna the flexible tubing may be twisted clockwise or counterclockwise as needed. Otherwise the tubing may be terminated in a manifold above the klystron and the wires, cable and tubes distributed as required so that individual components or groups may be selectively rotated.

[0035] In some embodiments, unlike conventional hydrofracturing operations, it is unnecessary to introduce water into the formation to create permeability enhancements. A focused beam is used to direct microwave energy in any direction to remove water and hydrocarbons plus increase permeability. Issues with injecting water that dissolves tight shale and decreases permeability are eliminated.

[0036] Several operational methodologies are possible using the HPM system depending on the type of well, the direct production of hydrocarbons, or the development of permeability zones surrounding the well to increase long term production. Relatively shallow vertical wells, down to about 2000 feet, in oil shale deposits of the Western United States and other locations can be drilled and the HPM system used to produce a very high percent of the hydrocarbons in a radial distance of 25 meters or more. Kerogen can be liquefied and pumped to the surface using submersible pumps. Gases collected at the surface can be either sold and/or used to power on site generators.

[0037] For deep shale deposits, microwaves can produce hydrocarbons or be used to increase the permeability surrounding hydrocarbon wells for future production. The HPM system can be used in a similar manner as multistage hydrofracturing where selected areas of the well are radiated to increase permeability in selected subsurface regions. Using

the HPM system, it is possible to increase the permeability of a cylinder 50 meters or more in diameter surrounding the well, to provide a large surface area interface between permeable rock created by microwave heating and the ambient hydrocarbon producing rock. The ability to direct microwave energy to any location in the subsurface provides flexibility in developing optimal production from various hydrocarbons subsurface reservoirs.

[0038] The apparatus and method of this invention provide an enhanced zone of intrinsic permeability surrounding bore holes that increases production rates for new or existing wells located in subsurface gas or petroleum reservoirs. A permeable skin region is created around the well bore that extends several meters radially from the well bore.

[0039] The system for extracting and recovering hydrocarbons from subsurface target formations may be a closed system downhole with pressure control to most effectively extract hydrocarbons from rock, such as oil shale. Oil shale typically contains a minimum of 2% to 4% of water. If there is insufficient water in the target formation, water may be added through an encased bore hole.

[0040] The water and/or other fluids, such as kerogen, in the target formation is superheated and causes fracturing of the rock. Further, the superheated fluid[s], from the target formation or added, causes the pressure to increase to push the liquified or volatized hydrocarbon to the surface. These hydrocarbons are collected in a tank and recovered.

[0041] Critical or superheated fluids, such as water which has a critical temperature of 647.3 degrees K. and a critical pressure of 218.3 atm. or methane which has a critical temperature of 190.4 degrees K at 45.4 atm. can be created either in-situ or added to the system to act as organic solvents to enhance hydrocarbon removal. The microwave recovery system controls downhole pressure and temperature necessary for the enhanced recovery of hydrocarbons via critical fluids.

[0042] The pressure created by the superheated water or steam may be controlled by controlling the microwave power applied to the antenna positioned in the target formation. Further, the frequency of the output of the microwave source may advantageously be 2.45 Gigahertz, which is the closest frequency to the resonance of water.

[0043] The above and other features, objects and advantages of this invention will become apparent from a consideration of the foregoing and the following description, the appended claims and the accompanying drawings.

[0044] Some embodiments of the downhole microwave system are illustrated in the drawings and will be described in detail herein. FIG. 1 illustrates the surface components of the downhole HPM system. A turbine generator 1, or similar source, at the surface of the well supplies electrical power for the system. The output of the electrical generator 1 is applied to an electrical control unit 2 that contains, but is not limited to, a crowbar, transformer, filter and power supply to provide DC power to the subsurface HPM system. DC power is connected to the downhole system through a flexible tube 3 via a coupler 4.

[0045] FIG. 3 illustrates a cross sectional view of the dual chamber flexible tube 3 that is used to lower the HPM system into the well and to retrieve the system out of the well, according to some embodiments of the present invention. The flexible tube 3 includes reinforced flexible tubing 25 capable of supporting the weight of the HPM system at depths consistent with conventional oil and gas wells. The interior of the flexible tubing 3 is divided by a septum 26 that creates dual

chambers 27 and 28. Tension cables can be added in the septum 26 if necessary to support the weight of the HPM system. One chamber 27 is used to input coolant, such as water, from the surface to the HPM system while the other chamber 28 is used for the return flow of heated water that is sent to a high capacity cooling system 6. An insulated DC power cable 29 is located in the center of the septum 26 to provide power to the klystron tube. Instrument cables 30, not limited to two, are also contained within the septum 26. The instrument cables provide information from, but not limited to, downhole instruments that monitor HPM location, arcing, temperature, and pressure, as well as a way of controlling downhole environment, operating conditions and components, like a carriage for up/down movement and rotation.

[0046] A pump 5 is connected to the dual chamber 27, 28 of tube 3 with the high capacity cooling system 6 to maintain an adequate supply of coolant, such as water, for the downhole HPM system.

[0047] FIG. 1 illustrates the HPM system is deployed downhole using a large motorized drum 7 capable of holding substantial lengths of flexible tubing and interchangeable with additional drums depending on the depths to be treated. A pulley 8 is connected to a well head manifold 9 and directs the HPM system into the well. A blow out preventer, common to oil and gas wells, is not shown. A compression assembly 10 secures the flexible tube 3 and provides an air tight seal during operation of the system.

[0048] The well head manifold 9 directs vapors from the well to a condenser 11 that collects hydrocarbon vapors or directs them to the power generator as a fuel source and/or to a separator for collection. A valve 12 is used to control downhole pressure for development of superheated fluids from in-situ water, or other in-situ fluids, to aid in the extraction of hydrocarbons. The system is attached to the well casing 13 that extends to the subsurface target area.

[0049] FIGS. 2 and 4 illustrate the major system components placed in the well, according to some embodiments of the present invention. An orientation tool 14 allows surface operators to place the radiating antenna 22 of the system at the desired depth within the target zone or area and to direct the antenna in the desired radiation direction. Alternatively, other positioning tools may be employed, such as the carriage shown in FIG. 5, or the like. Commonly used well field tools such as, but not limited to, gyroscopes or flux gate compasses provide the information for orientation of the system in various directions. The flexible tube 3 with dual coolant chambers and power and instrument cables is attached to a manifold 15 that directs power and the cooling system to the sheet beam klystron tube 16.

[0050] FIG. 5 illustrates one type of orientation tool, according to some embodiments of the present invention. A carriage 25 has three or more flexible arms 31 spaced at intervals around one or more of the components of the system. The intervals are preferably 130 degrees or 90 degrees. The carriage is shown attached to the klystron tube 16 in FIG. 5. Motorized rollers or wheels 32 engage the inner surface of the casing or low dielectric loss sleeve to move the system in the desired direction. The flexible arms 31 keep the wheels 32 in contact with the inner surface.

[0051] The size of the "down-hole" sheet beam klystron is limited by the size of the bore. For example, for an assumed bore diameter of 23 cm a sheet beam klystron can deliver a maximum power of 1 megawatt continuous wave (CW), which is more than twice the power of a conventional

klystron. This is because the cylindrical beam of a conventional klystron, at the same beam voltage (125 kV) could not be operated at the same current (17 Amps) because the dimensions of its beam would result in more current density than magnetic confinement of the beam could make possible. The sheet beam klystron tube **16** may be, but is not limited to, a 1 MW or greater sheet beam klystron tube at a frequency of, but not limited to, 6 to 8 GHz. The sheet beam klystron tube may be similar to one disclosed in U.S. Provisional Patent Application No. 61/633,730.

[0052] The typical steel casing in which the system of this application is used has a diameter of 9 inches. Other useful and relatively common casing sizes in which the system may be used have a 6 inch diameter or a 20 inch diameter.

[0053] Microwave power is emitted from the klystron tube **16** via a wave guide **17**, with an arc detector **18**, directly to a recirculator **19**. The waveguide **17** is a short waveguide that only has to be long enough to accommodate a dummy load **21** and connectors between the recirculator **19** and the klystron **16**. This places the source **16** near the antenna **22**, which is in the target zone. The main purpose of the recirculator **19** is to protect the klystron tube **16** by shifting the phase of reflected power to a separate output wave guide **20** connected with a water cooled dummy load **21**. Reflected power from the antenna **22** is coupled into cooling water to prevent damage to the klystron tube. Another major component of the downhole equipment is the directional antenna or applicator **22**. The antenna **22** is an applicator that is capable of radiating a directional beam in various radiation patterns to accomplish the desired fracture patterns. A water cooled phased array antenna provides the desired radiation pattern. Water tubes **23** provide coolant for the downhole system components. Other components which may be included are mode converters, additional arc detectors and monitoring equipment, for example.

[0054] FIGS. **4** and **2** illustrate one type of connection between the downhole components of the system. The waveguide **17** may be rectangular or some other appropriate configuration. Also, the dummy load **21** may be between the antenna **22** and the recirculator **19** and the waveguide **17** could then be shorter to couple the klystron tube **16** to the recirculator **19**.

[0055] In some embodiments, arc detectors are strategically placed in the waveguide to detect potential arcing problems and to immediately shut down the system if there is an arcing problem. The arc detectors and down hole sensors are integrated into the central control system **2** that monitors, but not limited to, electrical arcs, cooling water temperatures, off-gas temperatures, off-gas concentrations, and power conditions for the power supply and the klystron, and provides safety controls for the operation of the system.

[0056] Another component of the downhole system is a low dielectric loss sleeve **24** attached to the end of the well casing or steel pipe **13**. If the well bore is not encased, a low dielectric loss permeable sleeve **24** extends up the well and functions as the well casing to protect the system components in the open well bore not cased with steel pipe **13**. The sleeve may be comprised of, but not limited to, a perforated fused quartz or a ceramic cylinder that seats into a shoe at the base of the steel casing **13**. Several different applications are possible for emitting microwave radiation into the subsurface while protecting the downhole microwave system. Numerous holes in a fused

quartz or ceramic cylinder can be used to form the low dielectric loss sleeve that protects the equipment while radiating a subsurface target area.

[0057] Using well logging and geophysical data to select target zones, high power microwave energy is emitted from the antenna **22** in specific patterns to create migrating phase boundaries to fracture the rock and create specified zones of increased permeability. As a selected zone is completed, the sleeve **24** and the HPM system are pulled back to another target zone and the process repeated. An alternative to encasing the well down to the target area in steel, is to encase an extended portion or the whole well with a permeable low-loss well casing and to radiate either selected target zones or the entire target formation without moving the sleeve or casing.

[0058] Each sector to be radiated is selected to most efficiently extract the desired hydrocarbons from the target formation. The smaller the angle of the sector radiated the greater the energy in the sector. An angle of 30° is useful for most target formations. The angle of the sector may be increased or decreased when appropriate. The process is continued until the majority of the region at a selected depth has been radiated in all directions. The antenna **22** is either raised or lowered, or moved to the right or left in a horizontal well, in the casing **13** and sleeve **24** to another region in the target formation and the process of launching phase boundaries in sequenced sectors repeated. This process is continued until the distance of the phase boundary from the antenna **22** results in diminishing hydrocarbon recovery rates which will dictate cessation of the process in that sector and eventually at the operating depth of the antenna and in the particular bore hole.

[0059] The downhole microwave system is capable of removing nearly 100 percent of the water and volatile hydrocarbons. Careful laboratory measurement of the loss tangent for rock material that has been previously placed in a microwave field has shown that it is possible to effectively microwave and remove water and hydrocarbons in a cylinder conservatively predicted to be 50 meters in diameter and the length of the production zone. In horizontal wells, distances of one or two thousand meters for the production zone are not uncommon.

[0060] An important advantage of not introducing water into the well over hydraulic fracturing is the residual moisture left after hydrofracturing. Water introduced into a shale formation will cause some liquefaction or smearing of the shale reducing permeability at the fracture/shale interface. Once drilling fluids are removed from the well and the casing placed in the well to the depth of the target zone, no water is introduced into the well for the microwave process of this invention. Permeability enhancements remain constant during the life of the well since all water is removed in microwaved zones. Depletion in production rates will be reduced resulting in gas wells that produce high volumes of gas for longer durations.

[0061] In some embodiments, the method of inducing increased permeability at a selected target area downhole in an open well or an encased well comprises the steps lowering a system comprising the sheet beam klystron **16**, as the source of microwave energy, a directional antenna **22**, a recirculator **19** between the source and the antenna and a dummy load **21**. The recirculator directs reflected energy from the antenna **22** to the dummy load **21**. The system is lowered to a selected depth, in either a vertical or a vertical and horizontal well, and is then positioned with the antenna **22** in the target area and pointing in the selected direction. A low dielectric loss sleeve

or well casing around the antenna and source protect these components during and after fracturing. DC power is applied to the klystron **16** through a power cable **29** from the generator **1** on the surface. The DC voltage may be started at a selected lower level and increased to an operating level of 17 amps at 125 kilovolts. The increase may be in response to a measured parameter downhole or on a set schedule. Upon completion of the fracturing in the sector covered by the antenna, the antenna **22** is rotated to cover the next sector.

[0062] A coolant is recirculated from the surface through one chamber **27** in the flexible tubing **3**, downhole in contact with the source **22**, recirculator **19**, dummy load **21** and antenna **22** by way of coolant tubes **23** and then back to the surface through the second chamber **28** in the flexible tubing **3**.

[0063] The temperature of various components, the pressure of an enclosed well, the frequency of the source and flow rates and other parameters may be measured during and after fracturing.

[0064] There are several options for producing hydrocarbons from vertical or horizontal wells using the HPM microwave system. In vertical wells, microwave heating can begin at the bottom of the target zone and moved upwards. As hydrocarbons, such as kerogen in oil shale deposits are heated, liquid kerogen will flow downward and toward the bottom of the well where it can be collected and pumped to the surface. Once the kerogen is removed, the well can be completed as a conventional gas well. For horizontal wells, there are several options available to produce hydrocarbons. Multi-stage fracturing at selected intervals, similar to hydrofracturing, can be achieved using the microwave system. It is also possible to remove nearly 100 percent of the hydrocarbons in a cylinder surrounding a horizontal well for the entire length of the well within the target zone. The depth of the target area may be in excess of 10,000 feet with the antenna and the system being positioned at this depth.

[0065] The system does not require the use of large volumes of water or chemicals that could potentially impact the environment, or large quantities of sand, ail of which are necessary for a conventional hydrofracturing operation. The oil and gas industry relies on competent well construction to prevent potentially toxic chemicals used in hydrofracturing from contaminating valuable groundwater supplies. Effective disposal of water and chemicals used in hydrofracturing relies on cooperation between industry and the regulatory community. A breakdown in this process could result in a catastrophic release to the environment and large remediation costs. The high power microwave system relies on in-situ water and hydrocarbons to achieve fracturing of the rock. Outside sources of water or chemicals are not necessary for the performance of the high power microwave system. The costs of transport and disposal of hydrofracturing fluids is avoided and is a savings added in comparisons of technology efficiencies.

[0066] The presence of in-situ water provides another physical mechanism to improve hydrocarbon removal efficiencies. It is possible to control downhole temperatures and pressures with this microwave system. With the presence of water, super-heated steam can be created within the rock formations that will assist in stripping hydrocarbons from shale rocks.

[0067] The physical process of efficiently heating subsurface hydrocarbon deposits is based on launching a phase boundary in the subsurface using directed microwave energy,

thereby heating the hydrocarbon to temperatures where liquification or vaporization occurs. As hydrocarbons are removed, the remaining rock absorbs limited amounts of energy allowing the phase boundary to continue to migrate radially from the access well. This phase boundary may radiate out 25 meters or more.

[0068] The pressure and temperature may be controlled to provide the pressure and temperature at which selected fluids become critical or super critical fluids. For example, methane is often present in the subsurface area and the pressure may be established at or above 45.4 atmospheres with a temperature at or above 190.4 degrees K. to create a critical or super critical fluid of the methane which acts as an organic solvent to enhance hydrocarbon removal. The pressure and temperature may also be controlled to create a critical or super critical fluid of the water in the target area.

[0069] As an alternative to or in addition to pressure in the well, a sump near the bottom of the well with piping to the exterior of the well (not shown) may be used to recover the hydrocarbons and other liquids or gases from the bottom of the well.

[0070] The microwave system will produce significant fracture densities and wall cause solid blocks of shale to experience enhanced porous permeabilities from the radiation which will result in an increase of hydrocarbon production. Some photomicrographs of low permeable clay subjected to microwave heating show tracks or tunnels created by escaping gases. The effect of microwave heating results in solid blocks of shale showing significant increases in primary permeability in addition to increases in permeability due to fractures.

[0071] Microwave heating will result in hydrocarbons being liquefied and vaporized, and transported from deep within the earth via a permeable pathway created by microwave heating and under an enhanced gradient from high pressures deep within the earth to atmospheric pressure at the earth's surface. Throughout this journey, some of the vapor will be kept within the microwave field. However, this vapor absorbs very little energy and allows the bulk of the energy to heat rock. Primary separation of various hydrocarbons within the microwave field during transport from the rock and during vapor collection on the surface is possible with the microwave system. Separated or partially separated hydrocarbon compounds will significantly reduce refining costs further increasing the economic value of the High Power Microwave System.

[0072] Once downhole microwave treatment has been completed, there will be a large surface area interface between the permeable microwaved rock and hydrocarbon producing ambient or country rock. The high power microwave system has increased permeability and increased the surface area interface beyond the capabilities of hydrofracturing. More of hydrocarbon producing rock is exposed to permeable pathways allowing for the increased production from wells as compared to conventional hydrofracturing. Low permeable country rock that exhibits low hydrocarbon desorption rates have a large cross sectional area for hydrocarbons to flow through permeable rock to the well. A natural gas well capable of producing large volumes of gas for long periods of time will be the ultimate result after the microwave removal of hydrocarbons and permeability enhancement is completed. No toxic chemicals are injected into the ground.

There are no requirements for precious water resources or expensive disposal practices for the waste water and chemical.

[0073] Eventually, the highly permeable subsurface zones created by microwave treatment provide a reservoir for carbon sequestering. Carbon dioxide and other greenhouse gases can be sequestered in the same well that produced hydrocarbons by injecting these gases in liquid form back into the earth. This process may also be advantageous during active production where post-processed microwaved subsurface reservoirs are pressurized during carbon sequestering, thereby increasing the pressure gradient for active zones and forcing hydrocarbons into producing wells.

[0074] While the description above contains specificity, this should not be construed as limiting the scope of the invention; but merely as providing illustrations of the presently preferred embodiment of the invention. Although some embodiments and methods for extracting subsurface hydrocarbons have been described above, the inventions are not limited to the specific embodiments, but rather the scope of the inventions are to be determined as claimed.

What is claimed is:

1. A method of inducing increased permeability at a selected target area downhole in a well comprising lowering to the target area a system including a sheet beam klystron as the source of microwave energy, a recirculator, a dummy load, and a directional antenna.

2. The method in accordance with claim 1 further comprising positioning the antenna in the target area and pointing it in a selected direction to cover a selected sector.

3. The method in accordance with claim 2, further comprising applying DC power to the klystron through a power cable from a generator on the surface.

4. The method in accordance with claim 3, further comprising applying the DC voltage at a selected low level and then increasing the voltage to an operating level in response to a measured parameter downhole or on a set schedule.

5. The method in accordance with claim 3, further comprising employing a dual chamber flexible tube for lowering the system to the target area and recirculating a coolant from the surface through one chamber, downhole in contact with the source of microwave energy, recirculator, dummy load and antenna and back to the surface through the second chamber in the flexible tubing.

6. A method of intrinsic permeability enhancement at a selected subsurface level to release hydrocarbon liquids and gases at the selected subsurface level by employing a sheet beam klystron as the source of microwave energy coupled to a directional antenna, the method comprising positioning the source downhole near the directional antenna and positioning the directional antenna at the selected subsurface level and applying power to the source of microwave energy.

7. The method of intrinsic permeability enhancement at a selected subsurface level in accordance with claim 6, further comprising fracturing the rock at the selected level and increasing the rock permeability by increasing the interconnected porosity resulting in increased hydrocarbon delivery efficiency.

8. The method of intrinsic permeability enhancement at a selected subsurface level in accordance with claim 6, further comprising the further steps of fracturing the rock at the selected level and separating during fracturing selected hydrocarbons.

9. The method in accordance with claim 6, wherein a well has been drilled to a depth to reach the selected level, the method further comprising vaporizing a portion of the material at the selected subsurface level and creating a sufficient pressure differential between the area where the material is vaporized and the drilled well to push the hydrocarbons into and up the well.

10. The method in accordance with claim 6, further comprising applying microwave energy to form a phase boundary extending away from the antenna.

11. The method in accordance with claim 10, further comprising extending the phase boundary 25 meters or more from the antenna.

12. The method in accordance with claim 10, further comprising applying microwave energy at a sufficient density to vaporize a portion of the material in the phase boundary to create a pressure differential between the area in the phase boundary and the drilled well.

13. The method in accordance with claim 6, further comprising applying power from the surface through a cable to the source and circulating a coolant from the surface to the source and antenna.

14. The method in accordance with claim 6, further comprising positioning the antenna to cover a selected sector and rotating the antenna a selected number of degrees to cover another sector and applying power to the source.

15. The method in accordance with claim 6, further comprising closing the casing at the surface and controlling the temperature in the selected level.

16. The method in accordance with claim 6, further comprising closing the casing at the surface and controlling the pressure in the casing.

17. The method in accordance with claim 6, further comprising the producing superheated steam or other critical or super critical fluids in the target formation to enhance hydrocarbon removal rates.

18. A system for in-situ extraction of hydrocarbons from a target formation in a well comprising: a casing in the well, a well screen of low dielectric material at the lower end of the casing in the target formation, a source of microwave energy and a radiating antenna positioned in the casing at the target formation, and a short waveguide coupling the source of microwave energy to the antenna.

19. A system for creating a subsurface permeable cylinder by fracturing an unfractured rock at selected depths comprising a radiating antenna and a source of microwave energy near the antenna to expose a large surface area of unfractured rock to allow low hydrocarbon desorption rates that are compensated with large cross sectional areas for efficient and productive gas wells.

20. A method of creating a subsurface permeable cylinder as a reservoir comprising fracturing the rock at selected depths by a downhole system including a radiating antenna and a source near the antenna to expose a large surface area of unfractured rock to provide a reservoir and sequestering carbon in the reservoir.

21. The method of sequestering carbon in accordance with claim 20, further comprising pressurizing the reservoir and locating one or more hydrocarbon producing wells near the reservoir to enhance hydrocarbon production.